



Integrating IGCC with Existing PC Plants

A Presentation for Power Gen 2006

Gasification and Synfuels - Panel Discussion

November 30, 2006

Goals of Presentation

- **IGCC and PC typically thought of a mutually exclusive.**
- **Large O₂-blown gasification systems very difficult to integrate with PC units.**
- **With commercial development of air-blown gasification in scalable sizes, integration of IGCC and PC is practical.**
- **EPIC has a US Patent Pending on the concept(s) of integration of IGCC and PC.**
- **This presentation will show some possible configurations of IGCC/PC integration and the benefits of this integration.**

Typical Block Flow of The Gasifier System

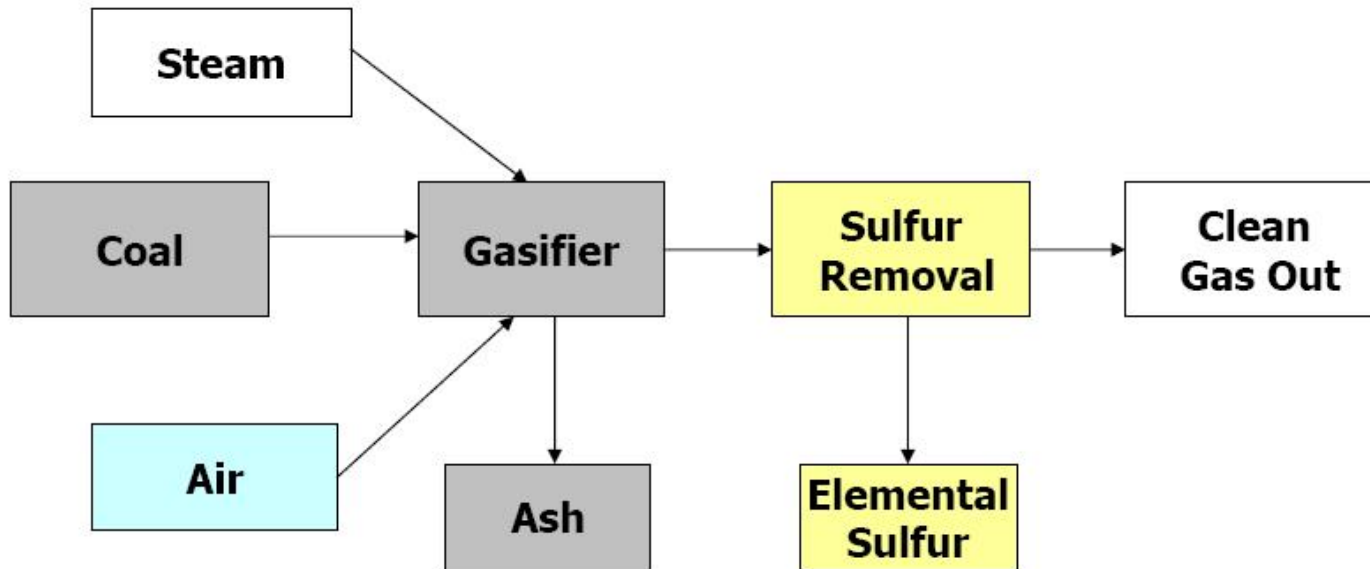

Typical Block Flow of EPIC IGCC Plant

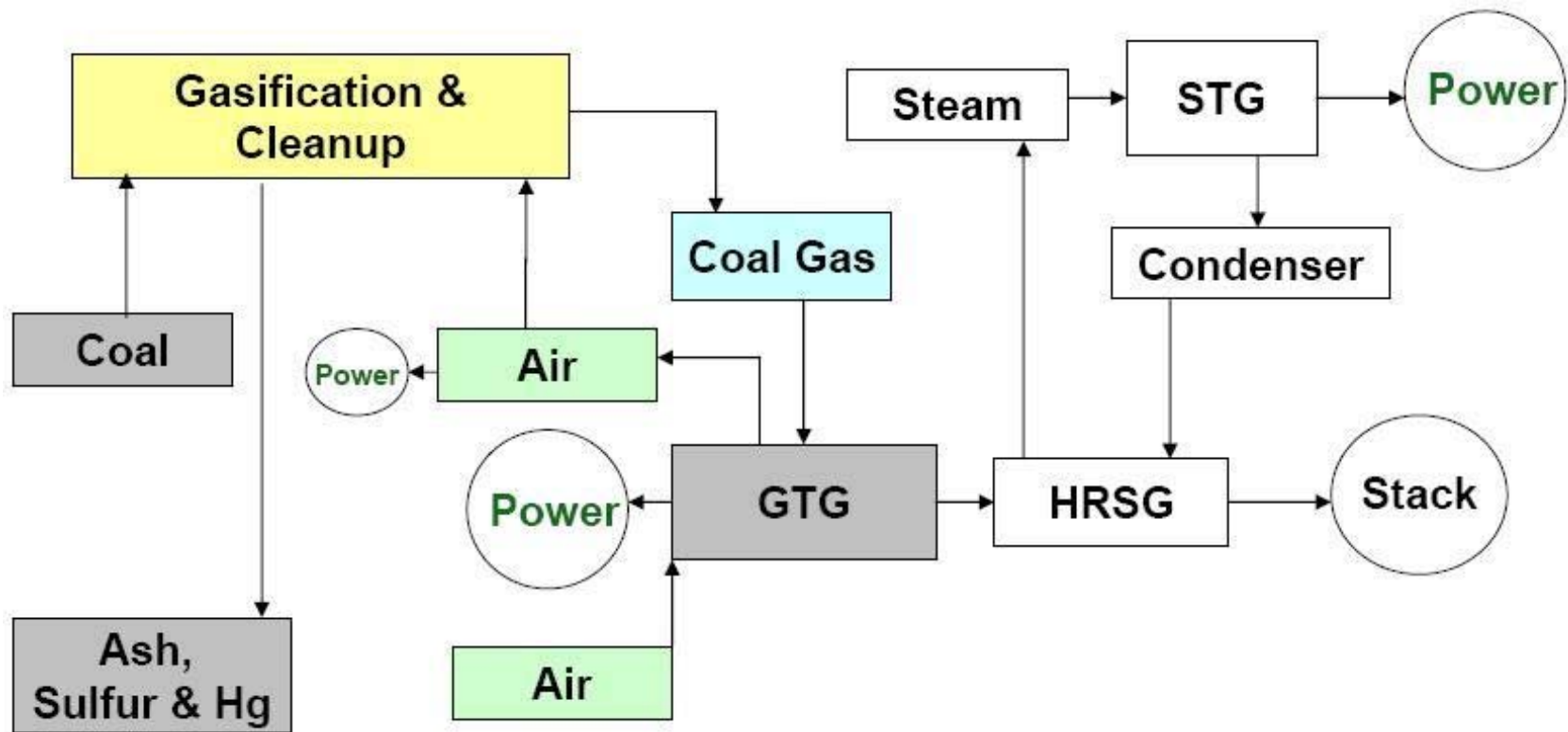

Typical Block Flow of PC Plant

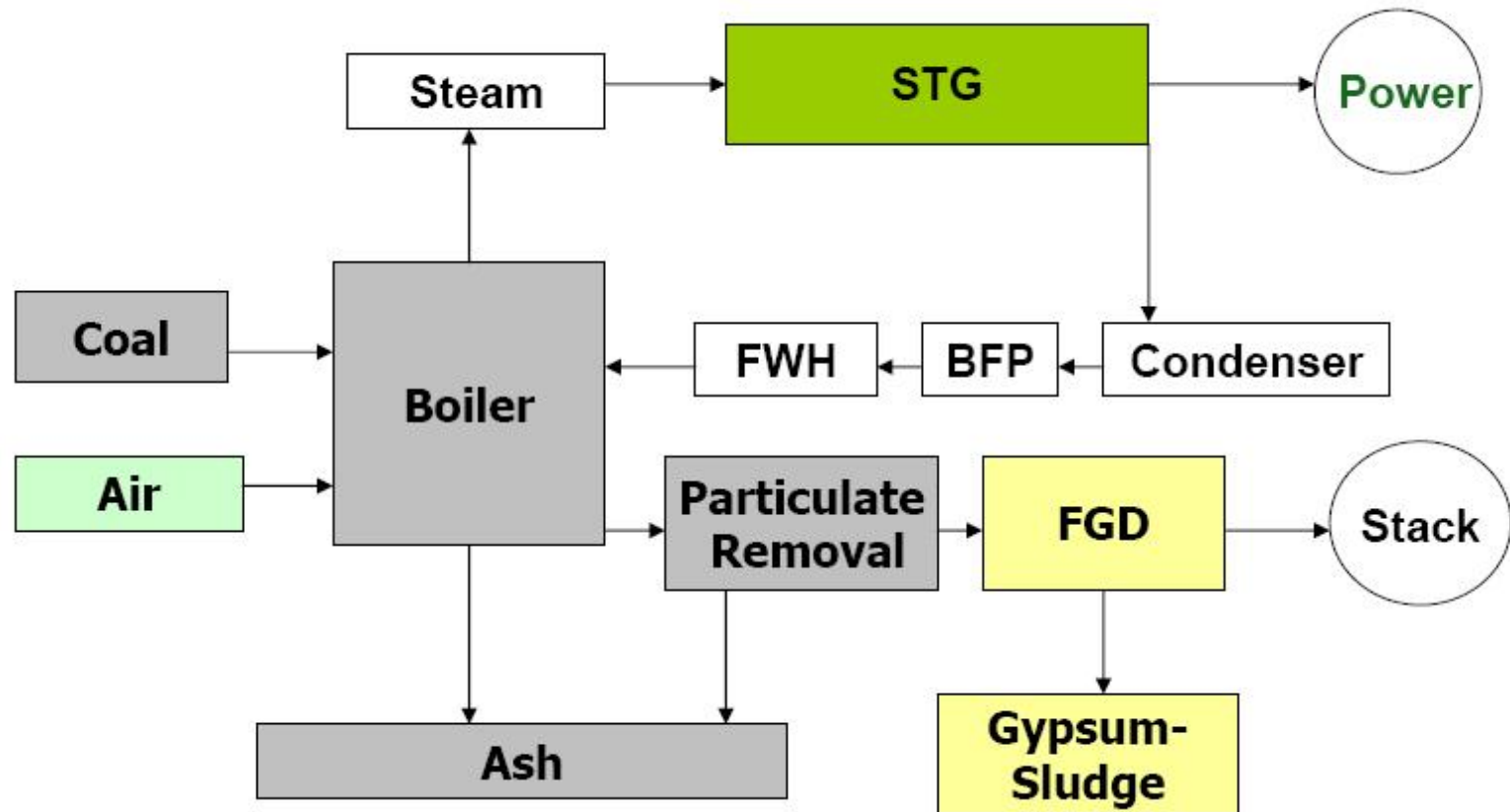

Possibility #1 - Zero Incremental Emissions

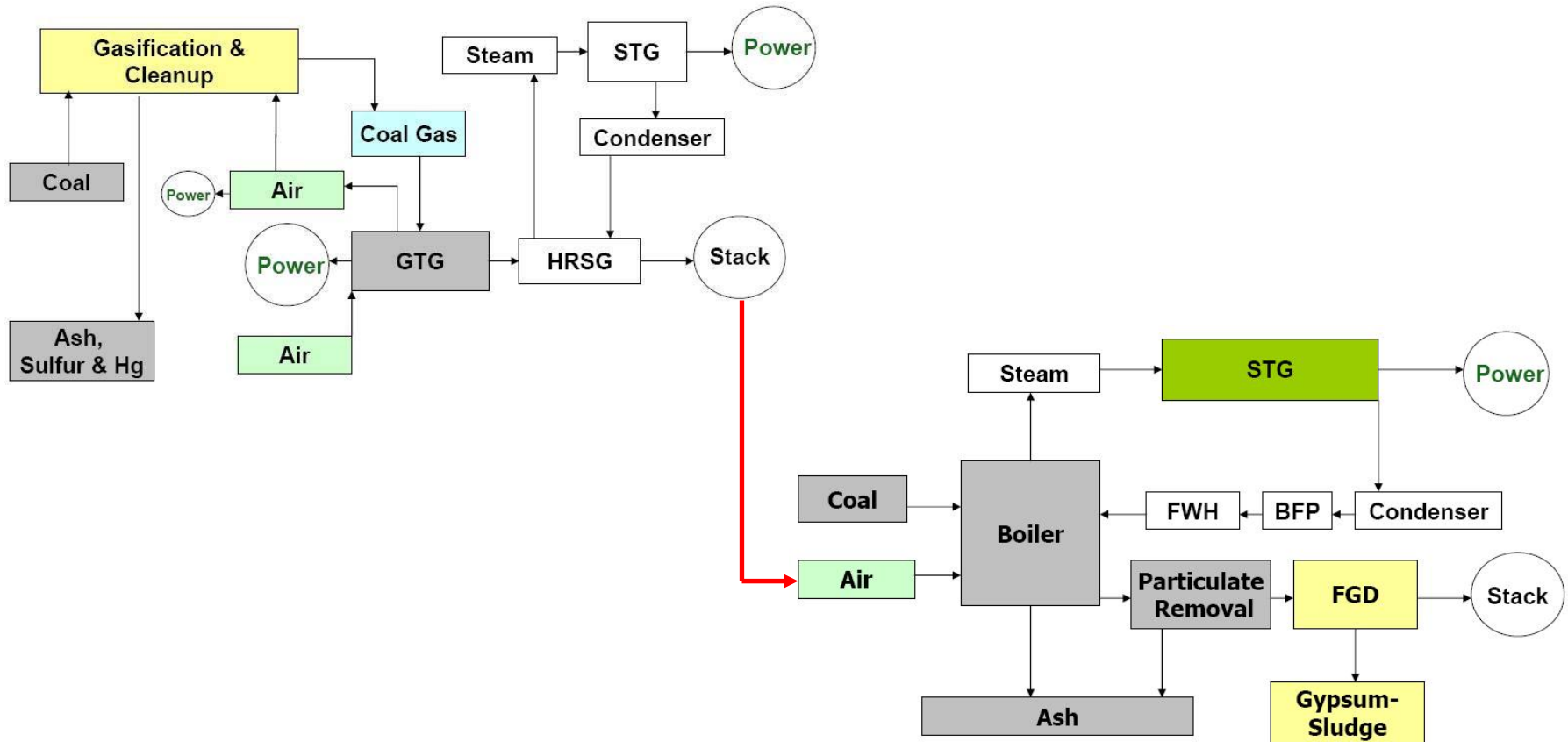

Possibility #2 – HRSG Steam to IP of STG

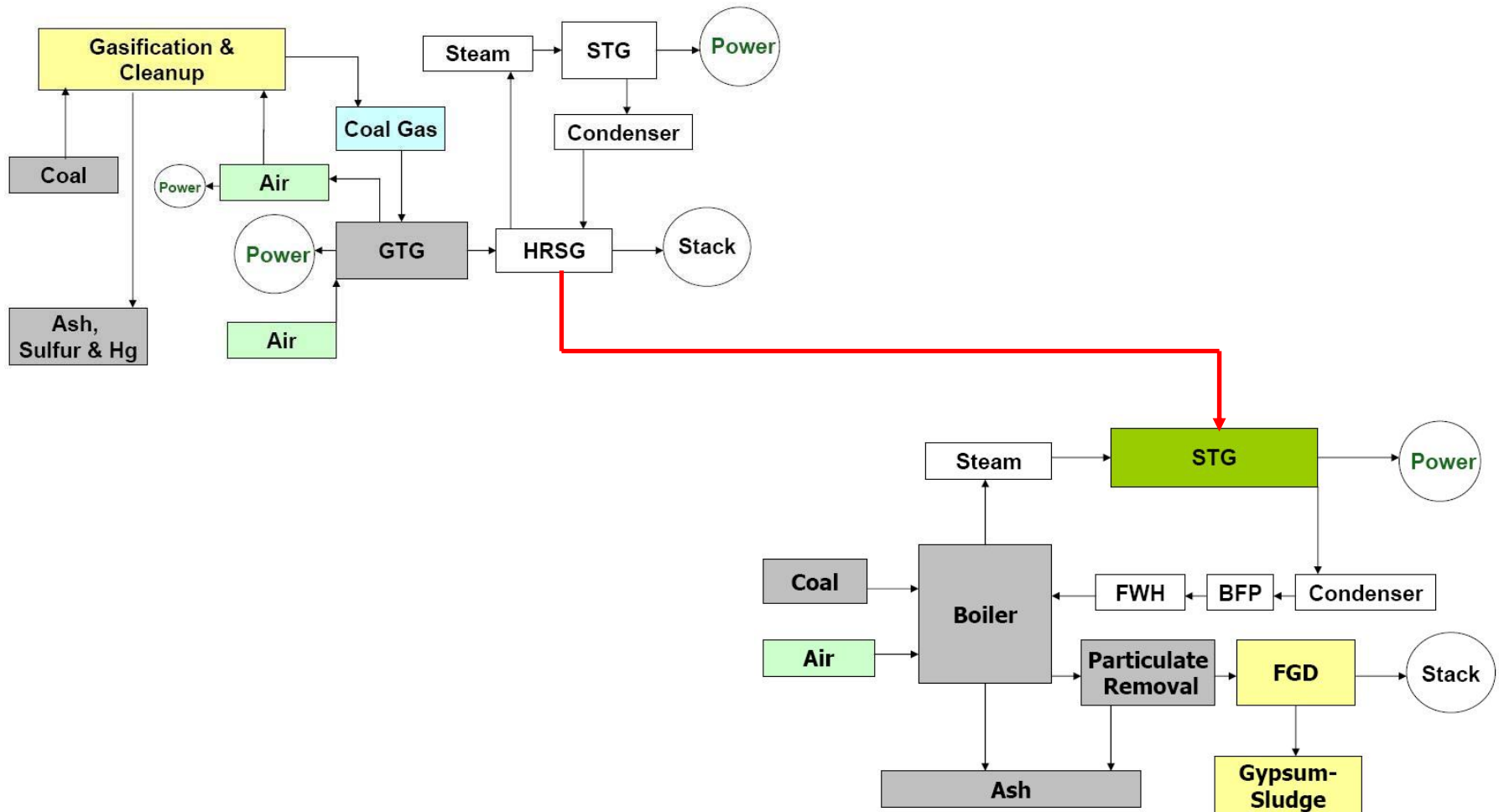

Possibility #3 - Zero Incremental Emissions + IP Steam Increase

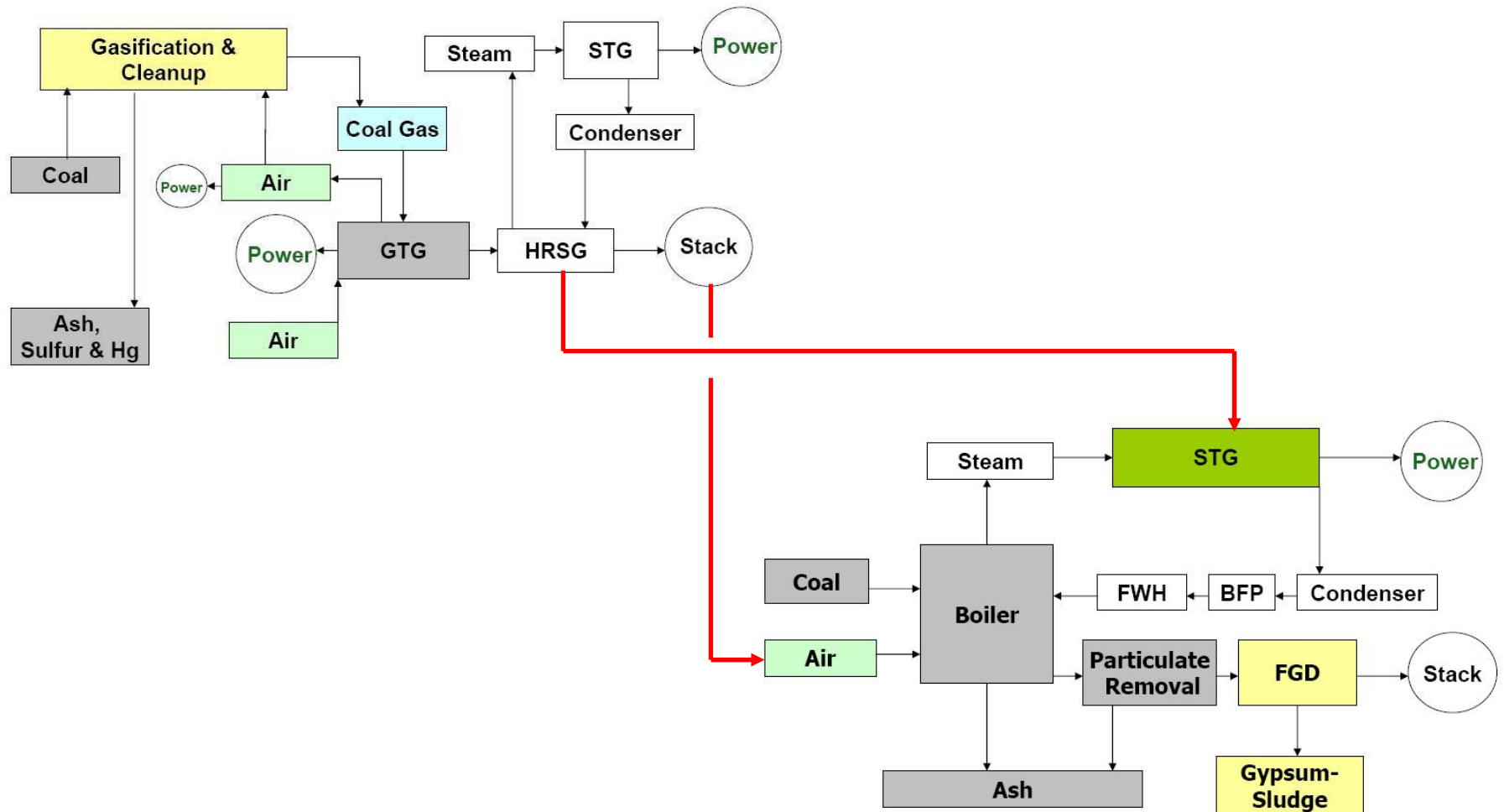

IGCC Assumptions

- **Frame 7EA GTG (ISO conditions)**
- **IGCC performance is net (including auxiliary losses)**
- **Unfired HRSG to meet STG IP/Reheat steam conditions**
- **Coal for gasification – PRB**
- **Heat rate is coal-in to power-out**

Table of Options for 250/400/800 MW

Case	Reheat PSIG/ ^o F	Original Steam to HP/IP	Incremental Steam to IP	Original kW	New STG kW	Incremental STG kW	GTG kW	New Net kW	Net Incremental kW	Net Incremental Heat Rate
270 MW	577/1050	1,548,500	299,000	272,000	324,100	52,100	76,800	400,900	128,900	8,520
400 MW	525/1000	2,438,900	269,600	409,000	451,200	42,200	76,800	528,000	119,000	9,200
800 MW	635/1050	4,720,900	299,400	873,000	917,000	44,000	76,800	993,800	120,800	9,100

Other Options to Integrate Gasification and PC

- **Auxiliary gasifiers to regain lost generation with high sulfur to PRB fuel switch**
- **Reheat flue gas for retrofit low-dust SCR and/or FGD**

Auxiliary Gasifiers - Recover Generation with Low S Conversion

- Install gasifiers as necessary to supplemental fire boiler with coal gas
- Direct NO_x benefit of 10-20% reduction
- Use of same coal as used in boiler

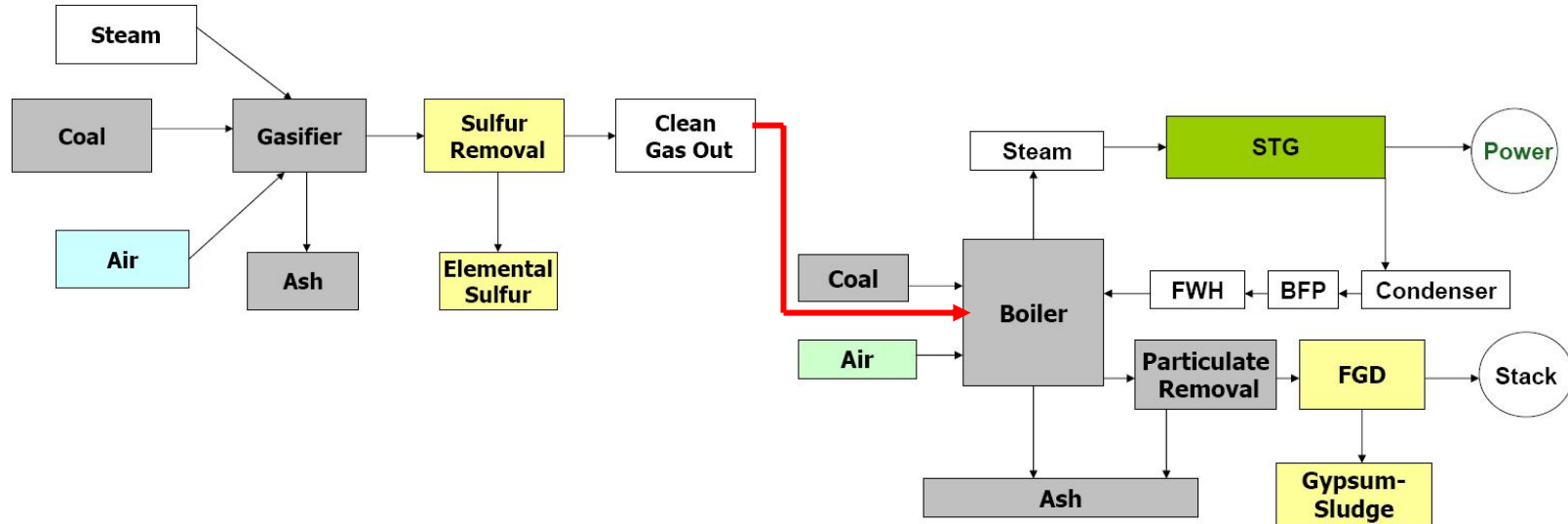

Reheat Flue Gas for Low Dust SCR and/or FGD With IGCC

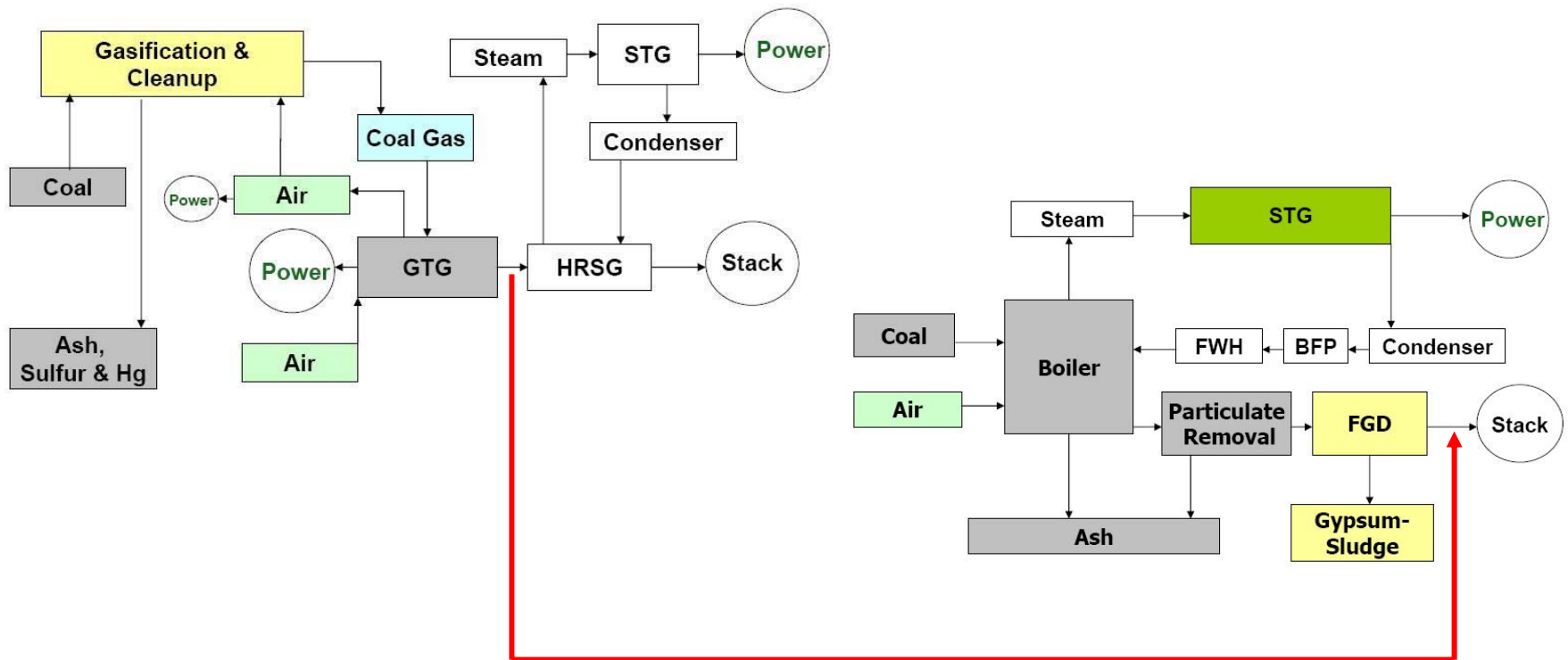

Conclusions

Many opportunities for IGCC (or air-blown gasification) integration with existing PC units:

- **Incremental power**
- **Improvement in efficiency/heat rate**
- **Decrease in emissions**
- **Asset utilization improvement**

EPIC Contacts

Econo-Power International Corp.

1502 Augusta, Suite 100

Houston, TX 77057

Telephone 713-979-5311

Fax 713-979-5322

Website – www.epic-power.com

David W. Wakefield – President

(email dwakefield@epic-power.com)

William C. Douglas – Sr. Vice President Business Development

(email bdouglas@epic-power.com)